



JOSLYN CLARK CONTROLS, LLC

CAPACITOR SWITCHING  
VACUUM CONTACTORS VS. AIR BREAK CONTACTORS  
APPLICATION PRECAUTIONS & CALCULATIONS TO LIMIT  
HIGH FREQUENCY & HIGH CURRENT INRUSH VALUES

JOHN S. LETT  
JOSLYN CLARK CONTROLS LLC  
LANCASTER, SC

QUESTION: WHY IS A VACUUM CONTACTOR A BETTER SWITCHING DEVICE WHEN SWITCHING CAPACITORS AND WHAT TYPICALLY ARE THE APPLICATION PROBLEMS AND CONSIDERATIONS?

When switching capacitors, whether they are low, medium or high voltage, precautions must be taken to insure that the in-rush current is limited to a non-destructive value. Likewise, the vacuum contactors or switches, in-rush currents should be limited, to levels below the contact blow open values.

It is well known that an uncharged capacitor bank offers practically zero impedance when energized, which results in a large high frequency transient in-rush current. When two or more capacitor banks are paralleled within close proximity to each other, the peak transient in-rush current to the uncharged bank may exceed the normal peak steady state capacitor current by several orders of magnitude. This high frequency explosive release of energy can cause damage to the switching device and capacitors, if it is not limited.

Usually reactors are applied to limit the surges; National Standards Organizations have set standards for calculating these values. In general, the lower the value the in-rush current is limited to, the longer will be the life of the switching device.

For Joslyn Clark's line of vacuum contactors, we recommend the following peak values limited as follows:

The CVC line of vacuum contactors:	200 amp	7kA
	400 amp	7kA
	600 amp	7kA

The VC line of vacuum contactors:	160 amp	9kA
	320 amp	9kA
	600 amp	9kA
	700 amp	9kA
	1000 amp	9kA

The MVC line of vacuum contactors:	200 amp	9kA
	400 amp	9kA
	600 amp	9kA
	800 amp	9kA
	1200 amp	9kA

Restrikes are the main problem associated in switching charged capacitor banks. This causes high over voltages and is damaging, usually critical to both the contactor and the capacitor. The contactor will have a habit of disappearing; the capacitor tank will swell and the capacitor fuses being frequently blown.

This phenomenon is caused by the contactor contacts not being open far enough at the first current zero on switch off. It is critical to have the contacts moving fast in opening, such that at the first zero crossing, the contacts are far enough apart and the dielectric strength good enough to prevent a discharge from the energized capacitor. Vacuum contactors are

particularly good at this type of performance because the environment is pure and constant with life; therefore, the only consideration is speed or velocity of contact movement.

However, with an air magnetic contactor, although the speed by design may be fast enough, the environment varies depending upon the cleanliness of the contact chamber and the environment that the contactor sits in. This gives different degrees of performance, and thus with usage it invariably gets worse, whereas in a vacuum device, it remains constant.

It is also important to remember that the contactor should not only be fast opening but also should be synchronized pole to pole switching three phase circuits, all Joslyn Clark vacuum contactors are fully synchronized and gang operated designed as a three phase contactor or switch.

Other safety considerations to equipment and personnel would also be included in any controlled equipment package such that there are delays between switching capacitor banks on and off such that charged capacitors bleed down before being re-energized or being bled down before personnel can access capacitor equipment terminals.

Calculations for current limited reactors, isolated or bank to bank switching

The only significant impedance to limiting inrush current is the inherent resistance and inductance of the conductors between capacitor banks. The values of resistance and inductance of these conductors may be too low to limit the in-rush current to a safe value. In these cases, the addition of current limited impedance is required. The use of reactors for this purpose has been found to be practical for most capacitor bank applications used on power systems. The following formula has been taken from the ANSI Standard C37.0731/1973. The formulas can be used to calculate inductance needed to limit peak in-rush currents to an acceptable value. In calculating the required inductance, it is generally safe to include a value of 0.3 micro henry per foot of overhead bus or 0.1 micro henry per foot of cable between capacitor banks. The resistance per foot is for the calculations assumed negligible. After the necessary inductance has been calculated, the inductance of the conductors between the banks is subtracted giving the size of inductance required for the current limited reactor.

Energizing an Isolated Capacitor Bank

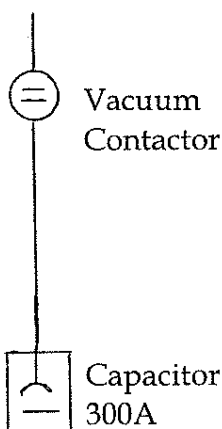

$$i \text{ max peak} = 1.41 \sqrt{I_{sc} \times I_1} = 1.41 \sqrt{20\text{kA} \times 300} = \underline{\underline{3525 \text{ AMP}}}$$

$$f \text{ (hertz)} = f_s \sqrt{\frac{I_{sc}}{I_1}} = 60 \sqrt{\frac{20000}{300}} = \underline{\underline{449 \text{ Hertz}}}$$

### Energizing a Bank with another on Same Bus

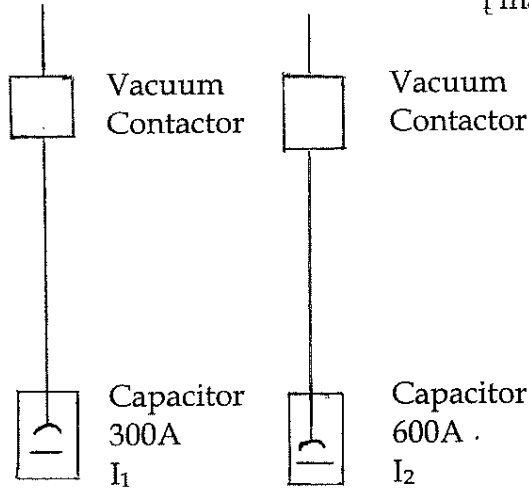

$$i \text{ max peak} = 1747 \sqrt{\frac{(V_L (I_1 \times I_2))}{L (I_1 + I_2)}} = 1747 \sqrt{\frac{.6 (300 \times 600)}{.1 (300 + 600)}}$$

$$= 2,156,916 \text{ A}$$

Increase Impedance to 10 MH<sub>1</sub> (Micro Henries)

$$= 1747 \sqrt{\frac{108000}{9000}}$$

$$\underline{6044 \text{ A}}$$

$$f = 9.5 \sqrt{\frac{(f_s) V_L (I_1 + I_2)}{(L) (I_1 \times I_2)}} = 9.5 \sqrt{\frac{60 \times .6 (300 + 600)}{10 (300 \times 600)}}$$

$$= 1.24 \text{ KHZ}$$

### Energizing a Bank with an Equal Bank Energized on Same Bank

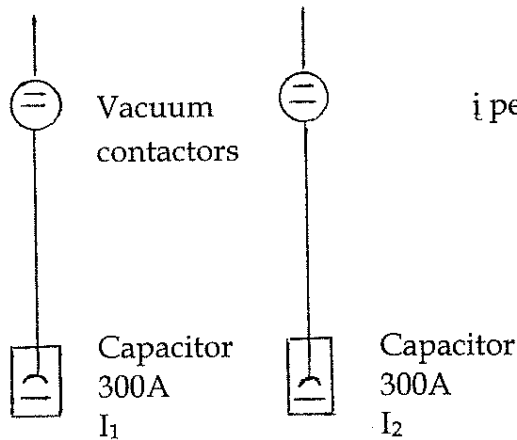

$$i \text{ peak} = 1235 \sqrt{\frac{(V_L) (I_1)}{L}} = 1235 \sqrt{\frac{0.6 \times 300}{10}}$$

$$= \underline{5236 \text{ A}}$$

$$f(\text{KHZ}) 13.5 \sqrt{\frac{(f_s) (V_L)}{(L) (I_1)}} = 13.5 \sqrt{\frac{60 \times 0.6}{10 \times 300}}$$

$$= \underline{1.48 \text{ KHZ}}$$

$f_s$  = System frequency (Hertz)

$L$  = Total required inductance/Phase between capacitor Banks in Micro Henries

$I_1 I_2$  = Current of Banks being switched and or bank already energized (current value should include effect of operating capacitor above normal voltage & capacitor tolerance) if unknown use 115% of normal capacitor current.

$i_{\max \text{ peak}}$  = Calculation without damping. In practical circuits it will be approximately 90% of calculated value.

$V_L$  = Rated Voltage in kilovolts

$I_{sc}$  = Symmetrical RMS short circuit current (A)