

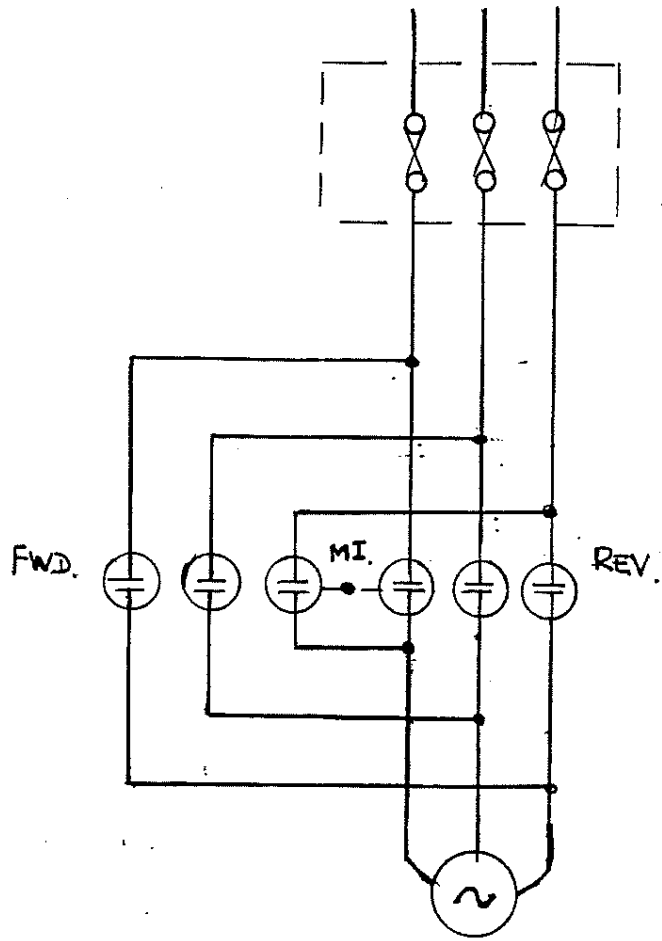

JOSLYN CLARK CONTROLS, INC.

THE APPLICATION OF REVERSING
VACUUM CONTACTORS ON CRANE
CONTROL APPLICATIONS

JOHN S. LETT



The Application of Reversing Vacuum Contactors on Crane Control Applications

Crane control applications are probably the most difficult application that can be applied to a contactor whether they be air magnetic contactors that have been traditionally used for many decades or most recently the use of compact vacuum contactors.

Cranes are typically used in tough industrial applications, for example, steel mills where the equipment is often subjected to rapid changes in temperature, i.e. environmental heat always exposed to dirt and dust contaminants, often subjected to crane vibration and the contactors themselves often see severe switching duty either as an AC3 duty rating starting and stopping a machine after full speed. Or AC4 duty where there is frequently starting and stopping the motor before it has reached full speed. It is not unusual to see a crane being used between 500,000 and a million operations or in excess per year. The equipment is frequently being used 24 hours a day and is mounted in an inaccessible service position on top of the crane and frequently the short circuit protection often abused as is discussed later is fed from a service feeder remote from the crane.

These service conditions resulted in air break contactors having to be serviced every month and sometimes more frequently. This was not only costly in terms of downtime but also in terms of replacement parts. It was not surprising therefore that manufacturers of vacuum contactors started to push their product into these type of applications and users started to retrofit existing equipment and install vacuum contactors on new crane applications. As with all new mouse traps that have an upside, there is also a downside to consider and the following discussion encompasses both the advantages in the use of vacuum contactors and the areas to be cautious about with the use of vacuum contactors. The user needs to carefully weigh these areas of caution to insure that he can manage an application successfully to take full advantage of the use of vacuum contactors in crane control applications.

The advantages of the vacuum contactor are that the interrupter is sealed in the vacuum chamber, hence the main power contacts are impervious to the harsh environment and the dirt and dust contaminants. The long electrical life of the contactor and high frequency of operation allows the contactor to handle the severe duty without the risk of welding that can frequently occur in air break contactors.

A typical 320 amp vacuum contactor should see at least a million electrical operations at AC3 duty at full rating. 320 amps at 480 volts equates to 250 horsepower which is probably well in excess of a typical crane motor horsepower which may range from 75 to 125 horsepower. At these horsepowers one could typically expect an electrically life of 2 to 2.5 million operations. The crane however is often subjected to AC4 duty which is starting and stopping a machine before it is up to full speed. Here the electrical life is typically reduced to 10% of its AC3 duty, therefore a contactor described previously doing 2 to 2.5 million operations would only do 200 to 250,000 operations if it was all AC4 switching.

Some intelligent estimates have to be given to each individual crane for each individual crane's function as to how much duty is seen at AC3 or AC4 on that particular portion of the crane to give the user an estimated electrical life.

Vacuum contactors also have a good mechanical life and these typically may be in excess of 2 to 3 million operations. It should also be noted that the mechanical operations will be affected by dirt and dust contaminants in a dirty environment and therefore some care should be taken in the installation to insure that the enclosures that house the contactors are wherever possible a NEMA 12 dust-tight enclosure and that doors are kept bolted shut and that any excess holes drilled in the enclosure are plugged to prevent the ingress of dust.

As mentioned earlier, it is not uncommon for a crane on certain functions to be performing 500,000 to 1 million or in excess of operations per year. Therefore based upon the above AC3, AC4 estimated operations, they only have an application life of 1 to 2 years on a heavily used crane. The user needs to be well aware of this in order that steps are taken in any preventative maintenance program to check contactors. The device could approach its end of electrical or mechanical life condition. If done properly these contactors can provide when compared to the frequency of air break contactor maintenance many times greater life expectancy. However, under this severe tough application they should not be regarded as maintenance free devices. A claim that is very true for probably 98% of vacuum contactor applications but is not true in the case of a crane control reverse application.

The areas of caution that need to be evaluated and investigated are

1. That adequate short circuit protection is provided for the contactor.
2. The risk of shoot through current on the reverse phase of the contactors is prevented.

Expanding on point one above the vacuum contactor is not a circuit breaker it has limited interrupt capability and must always be protected by an adequately protected and rated short circuit protection device either in the form of fuses or circuit breaker. Many crane control systems are fed from electrical systems having short circuit levels well in excess of a vacuum contactors interrupt capability which can typically be anywhere between 4 to 6,000 amps. If a short circuit occurs, this will be cleared by the short circuit protection device. In a reverse contactor application whether it be air break or vacuum, the risk of a short circuit occurring is much greater than on a conventional full voltage, across-the-line type starter and in the case of a vacuum contactor is considerably greater than that of an air break contactor.

The gaps associated with an air break contactor are much greater than that of a vacuum device and although both devices are mechanically interlocked, the mechanical interlock checks that the contactor that is open cannot close while the other contactor is fully closed. This means if one imagines a contactor say the "forward" contactor being closed then the reverse contactor is mechanically locked out and prevented from closing. The mechanical interlock checks for this condition, however, when the forward contactor starts to open and may only be now half open, mechanical interlock designs will allow the reverse contactor to start closing. Because of the small gaps that are involved with vacuum contactors, typically contact gaps are .080" to .100" (2 to 2 1/2mm). One can see that the risk of a short circuit occurring by the operator pushing the forward-reverse control buttons rapidly, or using a joy stick control switch rapidly and the risk of fault current on reverse phase is increased. Good designs of reversing control schemes will insure that this risk is minimized by sound mechanical and electrical control circuit interlocking.

Experience has shown that many crane control applications are not protected in accordance with National Electric Codes. These state that short circuit protection should not be greater than 175% of the branch circuit feeder current. Many cranes are often protected not individually but if it was say a three function crane protected by one upstream breaker feeding the crane. It may be rated as high as 6 or 700 amps. Such a high setting means that the breaker will take a long time or may never trip before the contactor is severely damaged and then the contactor acts as a fuse.

In addition, the situation is aggravated in so much that the short circuit through the forward and reverse contactors, reverse phase connection also occurs with one contact in the closed position and one contact in the open position. This open contact creates a further high impedance arc which will delay the trip time of the short circuit protection as it is limiting the rise time of the short circuit current.

Expanding on point 2 above, the control schemes should be developed to protect against an operator making rapid reversals and reduce the risk of a shoot through current described above. This risk is not only increased when a rapid reversal is attempted but there is no control regarding how many rapid reversals would be attempted, say in a 60 second period. The more frequent attempts that are made at AC4 switching will increase the risk of reducing the dielectric strength of the vacuum interrupter. Thus increasing the risk of shoot through current. This is a difficult phenomena to control but if good short circuit protection has been applied as in explanation 1 above, then the result would be nuisance tripping of the circuit breaker. Inadequate short circuit protection will result in damage to the vacuum interrupter which would result in downtime to repair and replace vacuum interrupters.

As expressed earlier crane control applications are probably the toughest application that a contactor can be applied to. With a well planned preventative maintenance program, correctly installed short circuit protection and an adequate control scheme with operators understanding the care needed to operate this equipment, the user will be able to enjoy the full advantages that vacuum contactors offer and see a 95% reduction in the downtime of ongoing costs of using air break contactors.

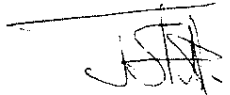

John S. Lett
Product Marketing & Sales Manager
Joslyn Clark Controls, Inc.
Lancaster, SC
July 27, 1995