

Diesel Engine Type

General

Joslyn Clark Diesel Fire Pump Controllers are designed and listed specifically for diesel engine driven fire pump service. These controllers meet or exceed all requirements of the National Fire Protection Association Standard NFPA 20, are listed by Underwriters Laboratories Inc., and approved by the Factory Mutual System.

The diesel controller provides four (4) major functions:

- Starts the diesel engine automatically from water pressure control or non-automatically from manual electric control.
- Monitors engine as well as system conditions.
- Maintains charge on engine starting batteries.
- Initiates a weekly test of the system

Standard Equipment

- Type 2 Drip Proof, Moisture Resistant enclosure with lockable, breakable cover for Mode Selector Switch, is suitable for wall or floor mounting. Painted with a UL Recognized Corrosion Resistant red baked enamel, for superior resistance to the damp corrosive environment of pump rooms.

- Visual indicators and audible alarms are provided to indicate the following:

AC Power ON	Automatic ON	Low Oil Pressure
#1 Or #2 Battery Fail	#1 or #2 Charger Fail	Safety Shut Down
Engine Overspeed	High Engine Temp	Engine Run
Pump Room Alarm	Weekly Test	Controller Trouble
Fail To Start	Deluge Valve/Remote Start	

- 2 SETS OF SPDT contacts for remote alarm of Engine Running, Engine Failure, Pump Room Alarm, and Controller Trouble. Single Contact for Switch in Auto and Single Contact for Switch in Manual or Off.
- Dual Battery chargers are switching type, solid state, 10 amp limiting.
- Built-in Printer provides a last 7 day review of Max, Min Pressures, Pressure Setpoints, Number of Starts, and pressure recorder interval. Pressure Recorder Printout for last 7 days available from printer.
- Programmable Weekly Timer to automatically start and run the engine for 30 minutes once a week.
- Internal plumbing and solenoid valve is rated for 500 PSI service.

Catalog Number System For Main Fire Pump Controllers

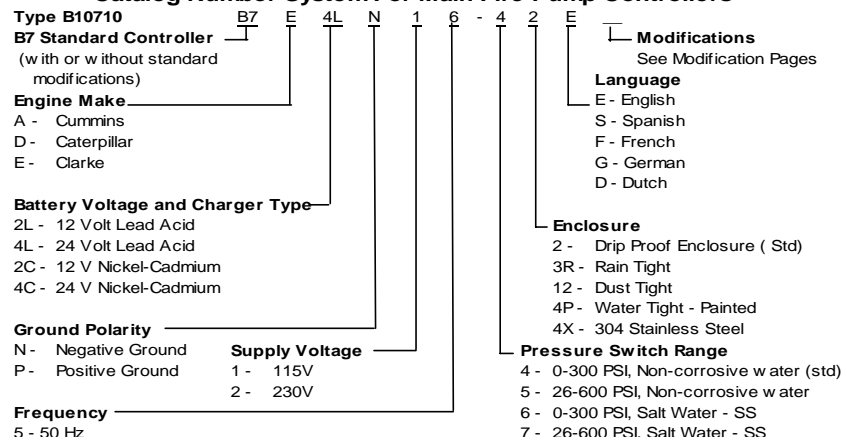

- Safety shut down circuit will shut down engine on “Low Oil Pressure” and “Engine Over-Temperature” if engine is running due to “Weekly Test or “AC Power failure”. An alarm will signal this condition.

- Two Manual “Start” pushbuttons are provided to crank from either battery or both at the same time for hard start conditions.

- LED’s (light emitting diodes) provide easy diagnostics of engine and controller interaction as well as charger and battery conditions.

Pump Room Alarms

- Low Suction Pressure
- Low Fuel Level
- Water Reservoir Low
- Water Reservoir Empty
- Low Pump Room Temperature
- High Fuel Level
- AC Failure